

# EMC TEST REPORT

Product Name: Multi-function ELECTRIC CLEANING BRUSH

Trade mark: /

Model No.: Q1, Q2, Q3, Q4, Q5, Q6, Q7, Q8, Q9, Q10

S/N: /

Report No.: CTB221124014EX

Applicant: Dongguan Shangyin Technology Co., Ltd

Address: Room501, Building 1, No. 11 Bulong Industrial First Road, Fenggang Town,  
Dongguan City, Guangdong Province

Manufacturer: Dongguan Shangyin Technology Co., Ltd

Address: Room501, Building 1, No. 11 Bulong Industrial First Road, Fenggang Town,  
Dongguan City, Guangdong Province

Prepared by: Shenzhen CTB Testing Technology Co., Ltd.

Address: 1&2/F., Building A, No.26, Xinhe Road, Xinqiao, Xinqiao Street, Bao'an  
District, Shenzhen, Guangdong, China

Date of Receipt: Nov. 21, 2022

Date of Test(s): Nov. 21, 2022 ~ Nov. 24, 2022

Date of Issue: Nov. 28, 2022

Test Standard(s): CFR47, FCC Part 15 Subpart B, ANSI C63.4: 2014

Test Result: Pass

In the configuration tested, the EUT complied with the standards specified above.

Compiled by:

*Blake Cai*

Blake Cai

Reviewed by:

*Zack Zhu*

Zack Zhu

Approved by:



Bin Mei

Note: If there is any objection to the inspection results in this report, please submit a written report to the company within 15 days from the date of receiving the report. The test report is effective only with both signature and specialized stamp. This result(s) shown in this report refer only to the sample(s) tested. Without written approval of Shenzhen CTB Testing Technology Co., Ltd. this report can't be reproduced except in full. The tested sample(s) and the sample information are provided by the client. "\*" indicates the testing items were fulfilled by subcontracted lab. "#" indicates the items are not in CNAS accreditation scope.

## Table of Contents

1.	Description of version .....	3
2.	Test summary.....	4
3.	Measurement uncertainty .....	5
4.	General information.....	6
4.1.	Description of EUT .....	6
4.2.	Description of accessory device .....	6
4.3.	Test conditions .....	6
4.4.	Block diagram of EUT configuration .....	6
4.5.	Operating condition of EUT .....	6
5.	List of Test and Measurement Instruments .....	7
6.	Conducted Emission .....	8
6.1.	Limit.....	8
6.2.	Test setup .....	8
6.3.	EMI test receiver setup .....	8
6.4.	Test procedure .....	8
6.5.	Test results .....	9
7.	Radiated emissions.....	11
7.1.	Limit.....	11
7.2.	Test setup .....	11
7.3.	EMI test receiver setup and spectrum analyzer setup .....	12
7.4.	Test procedure .....	12
7.5.	Corrected Amplitude & Margin Calculation.....	12
7.6.	Test results .....	13
8.	Photographs of test setup .....	15
9.	Photographs of EUT.....	16

## 1. Description of version

Report No.	Issue Date	Description	Approved
CTB221124014EX	Nov. 28, 2022	Original	Valid

## 2. Test summary

Test procedures according to the technical standards:

Standard	Test Item	Test Result
§15.107	Conducted Emission	PASS
§15.109	Radiated Emission	PASS

### 3. Measurement uncertainty

The reported uncertainty of measurement  $y \pm U$ , where expanded uncertainty  $U$  is based on a standard

Test Item	Frequency	Expanded Uncertainty ( $U_{Lab}$ )
Conducted Emission	150 kHz to 30 MHz	$\pm 3.2$ dB
Radiated Emission	30 MHz to 1000 MHz	$\pm 4.8$ dB

uncertainty multiplied by a coverage factor of  $k=2$ , providing a level of confidence of approximately 95 %

#### 4. General information

##### 4.1. Description of EUT

Product name	Multi-function ELECTRIC CLEANING BRUSH
Trade mark	/
Model No.	Q1
Serial Model No.	Q2, Q3, Q4, Q5, Q6, Q7, Q8, Q9, Q10
Model Difference	All model's the function, software and electric circuit are the same, only with a product color and model named different. Test sample model: Q1.
Rated Power	10W
Rated Voltage& current	DC 5V 1A
Configuration	<input checked="" type="checkbox"/> Table-top <input type="checkbox"/> Floor-standing
The highest frequency of the internal sources of the EUT	<input checked="" type="checkbox"/> below 1.705 MHz, the measurement shall only be made up to 30 MHz. <input type="checkbox"/> between 1.705 MHz and 108 MHz, the measurement shall only be made up to 1 GHz. <input type="checkbox"/> between 108 MHz and 500 MHz, the measurement shall only be made up to 1 GHz. <input type="checkbox"/> between 500 MHz and 1 GHz, the measurement shall only be made up to 1 GHz. <input type="checkbox"/> above 1 GHz, the measurement shall be made up to 5th harmonic of the highest frequency or 40 GHz, whichever is lower.
Adapter Information	/

**Note:** The above EUT information is declared by manufacturer and for more detailed features description, please refer to the manufacturer's specifications or the User's Manual.

##### 4.2. Description of accessory device

No.	Device Type	Brand	Model	Specification	Note
1	ADAPTER	JIYIN	JY-05100C	/	/

##### 4.3. Test conditions

Temperature: 15-25°C  
 Relative Humidity: 30-60 %  
 Atmospheric pressure: 800hPa-1060hPa

##### 4.4. Block diagram of EUT configuration

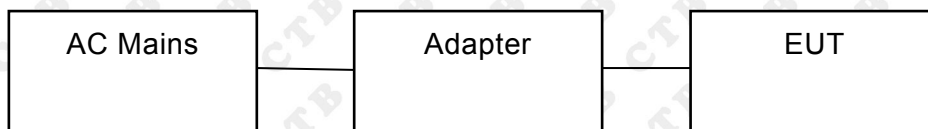

##### 4.5. Operating condition of EUT

Operating condition	Mode 1	Charging	Test Voltage	AC 120V/60Hz
	Mode 2*	Working	Test Voltage	DC 3.7V

Note: This test covers all possible operating modes of the device, only the worst data are list in report. The worst data are shows (\*) is the nearest standard limit which were recorded in this report.

**5. List of Test and Measurement Instruments**

Continuous disturbance					
No.	Equipment	Manufacturer	Model No.	Serial No.	Calibrated until
1	843 Shield Room	C/ R/ T	843	/	2024/8/11
2	AMN	ROHDE&SCHWARZ	ESH3-Z5	831551852	2023/7/19
3	Pulse limiter	ROHDE&SCHWARZ	ESH3Z2	357881052	2023/7/19
4	EMI TEST RECEIVER	ROHDE&SCHWARZ	ESCS30	834115/006	2023/7/19
5	Coaxial cable	ZDECL	Z302S	18091904	2023/7/19
6	AAN	Schwarzbeck	NTFM8158	183	2023/7/19
7	EZ-EMC	Frad	EMC-con3A1.1	/	/

Radiated emission					
No.	Equipment	Manufacturer	Model No.	Serial No.	Calibrated until
1	966 Chamber	C/ R/ T	966	/	2024/8/11
2	Double Ridged Broadband Horn Antenna	Schwarzbeck	BBHA 9120D	1911	2023/7/23
3	TRILOG Broadband Antenna	Schwarzbeck	VULB 9168	869	2023/7/22
4	Amplifier	Agilent	8449B	3008A01838	2023/7/19
5	Amplifier	HP	8447E	2945A02747	2023/7/19
6	EMI TEST RECEIVER	ROHDE&SCHWARZ	ESPI7	100362	2023/7/25
7	Coaxial cable	ETS	RFC-SNS-100-NMS-80 NI	/	2023/7/19
8	Coaxial cable	ETS	RFC-SNS-100-NMS-20 NI	/	2023/7/19
9	Coaxial cable	ETS	RFC-SNS-100-SMS-20 NI	/	2023/7/19
10	Coaxial cable	ETS	RFC-NNS-100-NMS-300 NI	/	2023/7/19
11	EZ-EMC	Frad	EMC-con3A1.1	/	/

## 6. Conducted Emission

### 6.1. Limit

Except for Class A devices:

Frequency of emission (MHz)	Conducted limit (dB $\mu$ V)	
	Quasi-peak	Average
0.15-0.5	66 to 56*	56 to 46*
0.5-5	56	46
5-30	60	50

**Note:** Decreases with the logarithm of the frequency.

For Class A devices:

Frequency of emission (MHz)	Conducted limit (dB $\mu$ V)	
	Quasi-peak	Average
0.15-0.5	79	66
0.5-30	73	60

### 6.2. Test setup

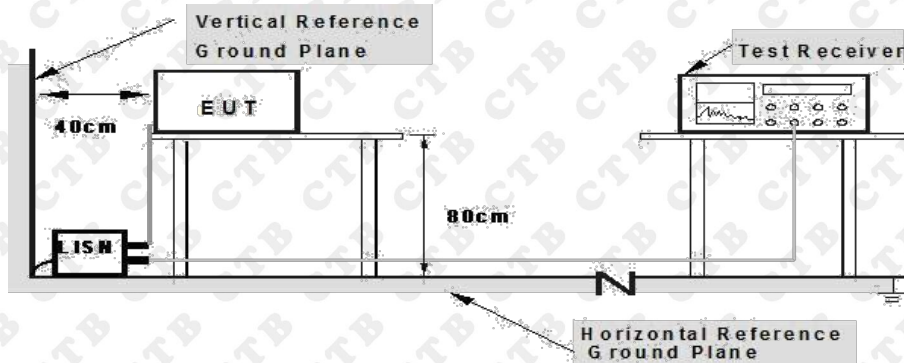

**Note:** 1. Support units were connected to second LISN.  
 2. Both of LISN's (AMN) are 80 cm from EUT and at least 80 from other units and other metal planes

The setup of EUT is according with ANSI C63.4 measurement procedure. Specification used with FCC Part 15 limits.

### 6.3. EMI test receiver setup

Frequency Range	9kHz-30MHz
Resolution Bandwidth	200Hz (9kHz-150kHz) 9kHz (150kHz-30MHz)

### 6.4. Test procedure

1. Measurement was performed in shielded room, and instruments used were followed clause 4 of ANSI C63.4.
2. Detailed test procedure was following clause 7 of ANSI C63.4.
3. Frequency range 150kHz – 30MHz was checked and EMI receiver measurement bandwidth was set to 9 kHz.



## 6.5. Test results

Temperature:	23°C	Relative Humidity:	54 %
Pressure:	101kPa	Phase :	Line
Test Voltage :	AC 120V/60Hz	Test Mode:	Mode 1

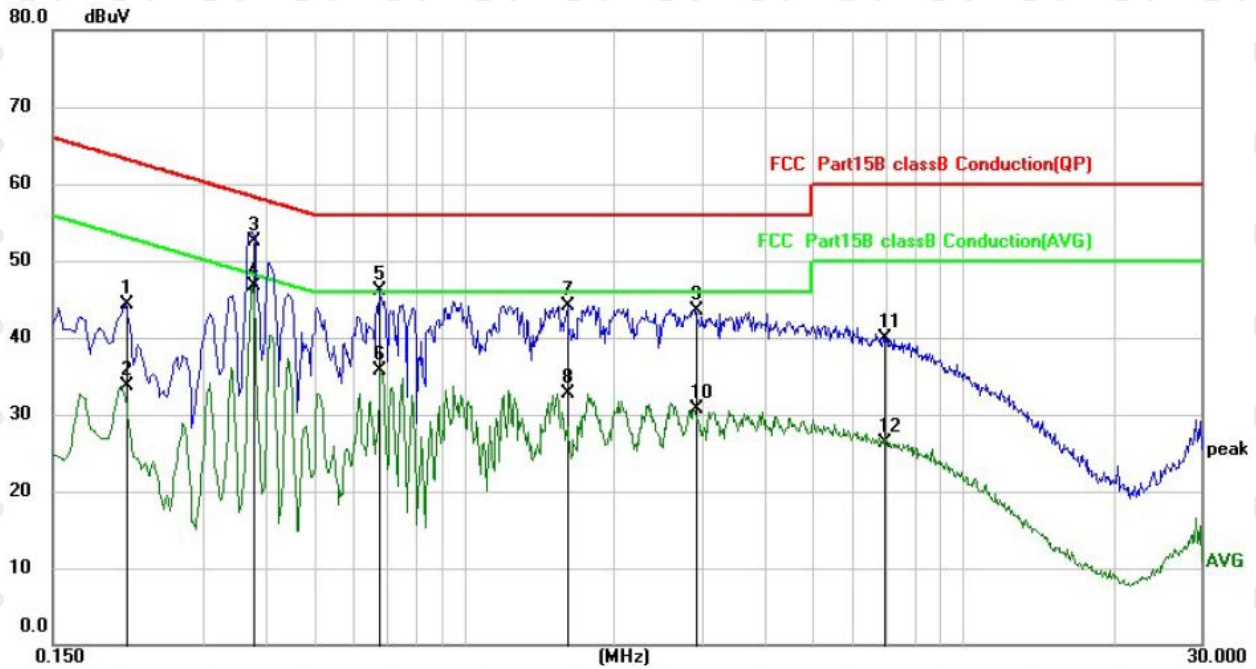

No.	Mk.	Freq. MHz	Reading Level dBuV	Correct Factor dB	Measurement dBuV	Limit dBuV	Over dB	Detector
1		0.2100	34.34	10.00	44.34	63.21	-18.87	QP
2		0.2100	23.74	10.00	33.74	53.21	-19.47	AVG
3		0.3780	42.60	9.98	52.58	58.32	-5.74	QP
4	*	0.3780	36.79	9.98	46.77	48.32	-1.55	AVG
5		0.6780	36.04	9.97	46.01	56.00	-9.99	QP
6		0.6780	25.69	9.97	35.66	46.00	-10.34	AVG
7		1.6180	34.19	10.01	44.20	56.00	-11.80	QP
8		1.6180	22.62	10.01	32.63	46.00	-13.37	AVG
9		2.9100	33.53	10.07	43.60	56.00	-12.40	QP
10		2.9100	20.64	10.07	30.71	46.00	-15.29	AVG
11		6.9300	29.75	10.24	39.99	60.00	-20.01	QP
12		6.9300	16.11	10.24	26.35	50.00	-23.65	AVG

Note: Result=Reading + Factor  
Over Limit=Result - Limit

Temperature:	23°C	Relative Humidity:	54 %
Pressure:	101kPa	Phase :	Neutral
Test Voltage :	AC 120V/60Hz	Test Mode:	Mode 1

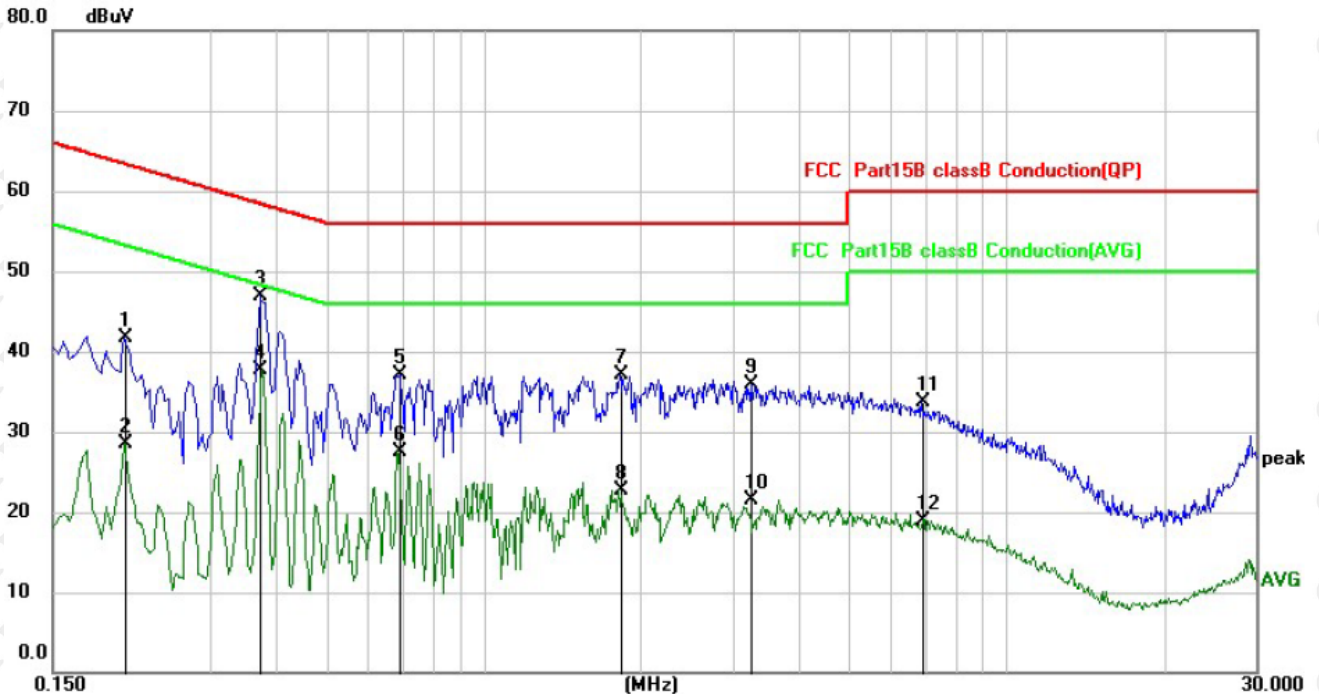

No.	Mk.	Freq. MHz	Reading Level dBuV	Correct Factor dB	Measure- ment dBuV	Limit dBuV	Over dB	Detector
1		0.2060	31.70	10.00	41.70	63.37	-21.67	QP
2		0.2060	18.52	10.00	28.52	53.37	-24.85	AVG
3		0.3740	36.87	9.98	46.85	58.41	-11.56	QP
4	*	0.3740	27.68	9.98	37.66	48.41	-10.75	AVG
5		0.6900	27.05	9.97	37.02	56.00	-18.98	QP
6		0.6900	17.63	9.97	27.60	46.00	-18.40	AVG
7		1.8220	27.14	10.02	37.16	56.00	-18.84	QP
8		1.8220	12.78	10.02	22.80	46.00	-23.20	AVG
9		3.2460	25.73	10.09	35.82	56.00	-20.18	QP
10		3.2460	11.35	10.09	21.44	46.00	-24.56	AVG
11		6.9020	23.52	10.24	33.76	60.00	-26.24	QP
12		6.9020	8.61	10.24	18.85	50.00	-31.15	AVG

Note: Result=Reading + Factor  
Over Limit=Result – Limit

## 7. Radiated emissions

### 7.1. Limit

Except for Class A devices (at 3m):

Frequency of emission (MHz)	Field strength (microvolts/meter)	
	(microvolts/meter)	(dB $\mu$ V/m)
30-88	100	40
88-216	150	43.5
216-960	200	46
Above 960	500	54

For Class A devices (at 10m):

Frequency of emission (MHz)	Field strength (microvolts/meter)	
	(microvolts/meter)	(dB $\mu$ V/m)
30-88	90	39
88-216	150	43.5
216-960	210	46.4
Above 960	300	49.5

### 7.2. Test setup

Radiated Emission Test Set-Up Frequency Below 1 GHz

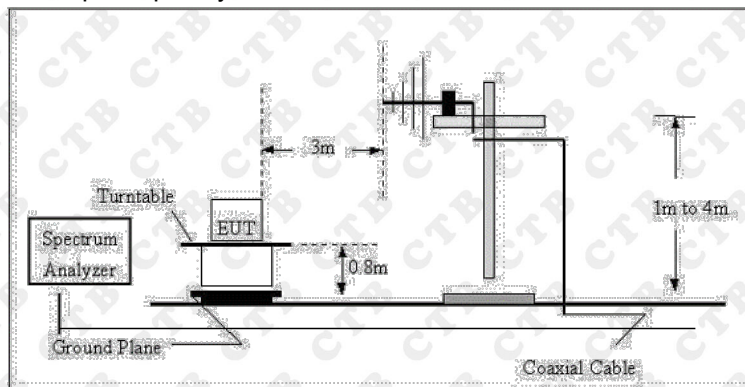

Radiated Emission Test Set-Up Frequency Above 1GHz

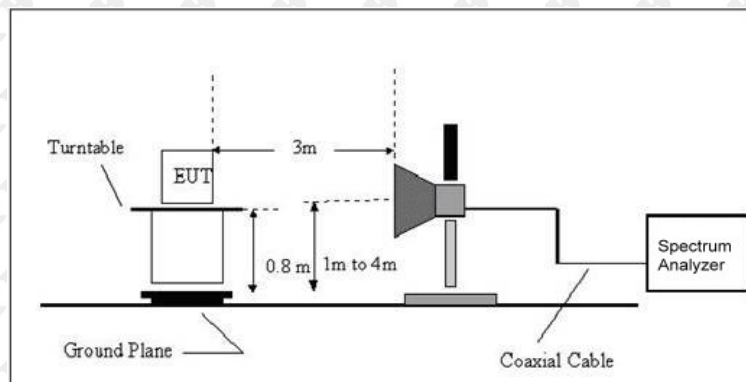

The radiated tests were performed in 3 meter Chamber test site, using the setup accordance with the ANSI C63.4:2014.

### 7.3. EMI test receiver setup and spectrum analyzer setup

During the radiated emission test, the EMI test receiver and Spectrum Analyzer were set with the following configurations:

Frequency Range	RBW	Video B/W	IF B/W	Detector
30MHz-1000MHz	100kHz	300kHz	120kHz	QP
Above 1GHz	1MHz	3MHz	/	PK
	1MHz	10Hz	/	AVG

### 7.4. Test procedure

1. The measurement was performed in a semi-anechoic chamber, and instruments used were followed clause 4 of ANSI C63.4
2. Detailed test procedure was following clause 8 of ANSI C63.4.

### 7.5. Corrected Amplitude & Margin Calculation

1. The Corrected Amplitude is calculated by adding the Antenna Factor and Cable Loss, and subtracting the Amplifier Gain from the Meter Reading. The basic equation is as follows:

$$\text{Corrected Amplitude} = \text{Meter Reading} + \text{Antenna Factor} + \text{Cable Loss} - \text{Amplifier Gain}$$

2. The "Margin" column of the following data tables indicates the degree of compliance with the applicable limit. For example, a margin of 7dB means the emission is 7dB below the limit. The equation for margin calculation is as follows:

$$\text{Margin} = \text{Limit} - \text{Corrected Amplitude}$$

## 7.6. Test results

Temperature:	23°C	Relative Humidity:	54 %
Pressure:	101kPa	Polarization :	Horizontal
Test Voltage :	DC 3.7V	Test Mode:	Mode 2

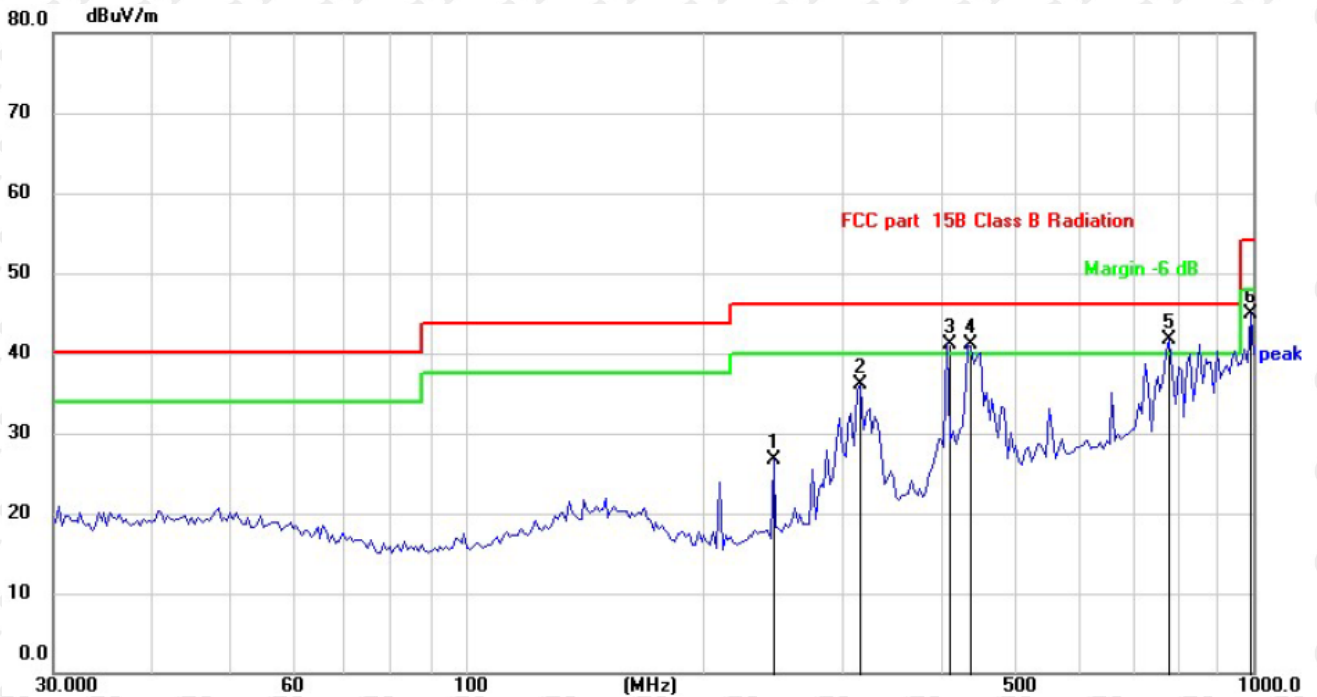

No.	Mk.	Freq. MHz	Reading Level dBuV	Correct Factor dB	Measure- ment dBuV/m	Limit dB/m	Over dB	Detector
1		245.9509	34.71	-8.00	26.71	46.00	-19.29	QP
2		317.1445	41.04	-4.98	36.06	46.00	-9.94	QP
3	!	408.9460	43.60	-2.40	41.20	46.00	-4.80	QP
4	!	434.8268	42.86	-1.71	41.15	46.00	-4.85	QP
5	*	782.3453	36.19	5.44	41.63	46.00	-4.37	QP
6		991.2719	36.71	8.13	44.84	54.00	-9.16	QP

Note: Result=Reading+Factor  
Over Limit=Result-Limit

Temperature:	23°C	Relative Humidity:	54 %
Pressure:	101kPa	Polarization :	Vertical
Test Voltage :	DC 3.7V	Test Mode:	Mode 2

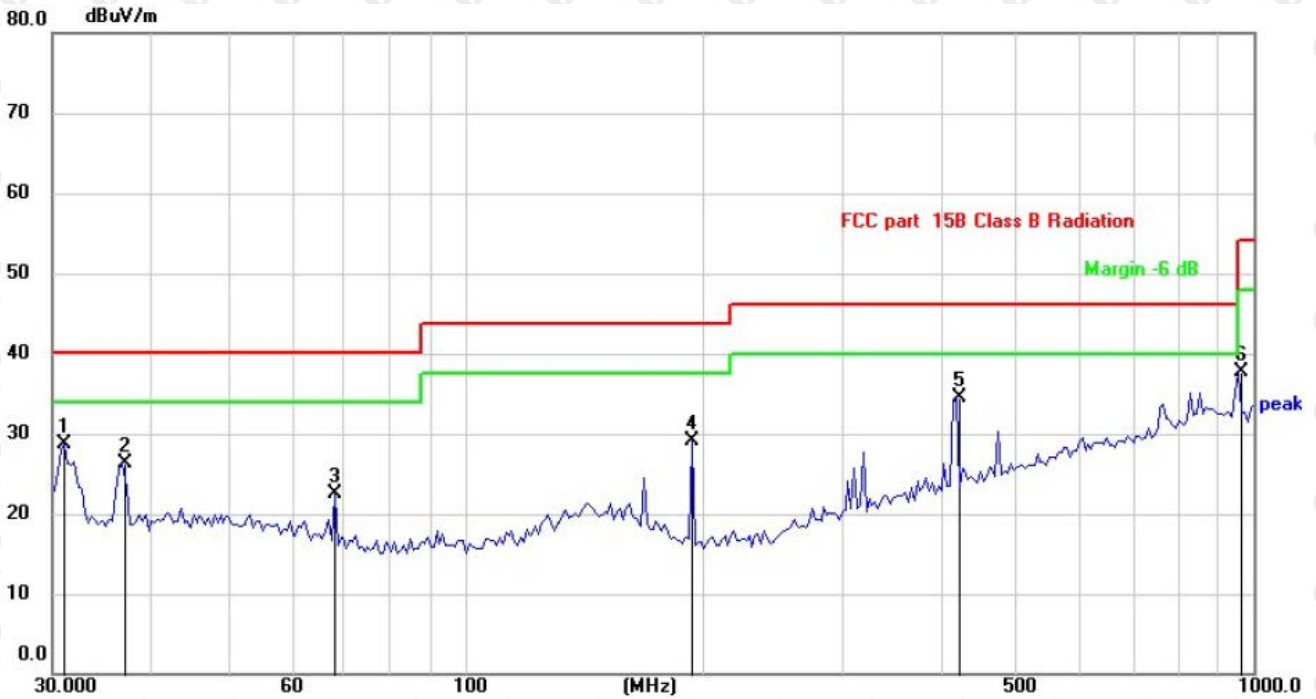

No.	Mk.	Freq. MHz	Reading Level dBuV	Correct Factor dB	Measure- ment dBuV/m	Limit dB/m	Over dB	Detector
1		31.0706	35.57	-6.86	28.71	40.00	-11.29	QP
2		36.7018	32.82	-6.57	26.25	40.00	-13.75	QP
3		68.3908	31.40	-8.83	22.57	40.00	-17.43	QP
4		194.1128	38.36	-9.19	29.17	43.50	-14.33	QP
5		419.8436	36.64	-2.11	34.53	46.00	-11.47	QP
6	*	957.1148	30.03	7.73	37.76	46.00	-8.24	QP

Note: Result=Reading+Factor  
Over Limit=Result-Limit

## 8. Photographs of test setup

RE



CE



## 9. Photographs of EUT

EUT photo 1



EUT photo 2





EUT photo 3



EUT photo 4



EUT photo 5



EUT photo 6

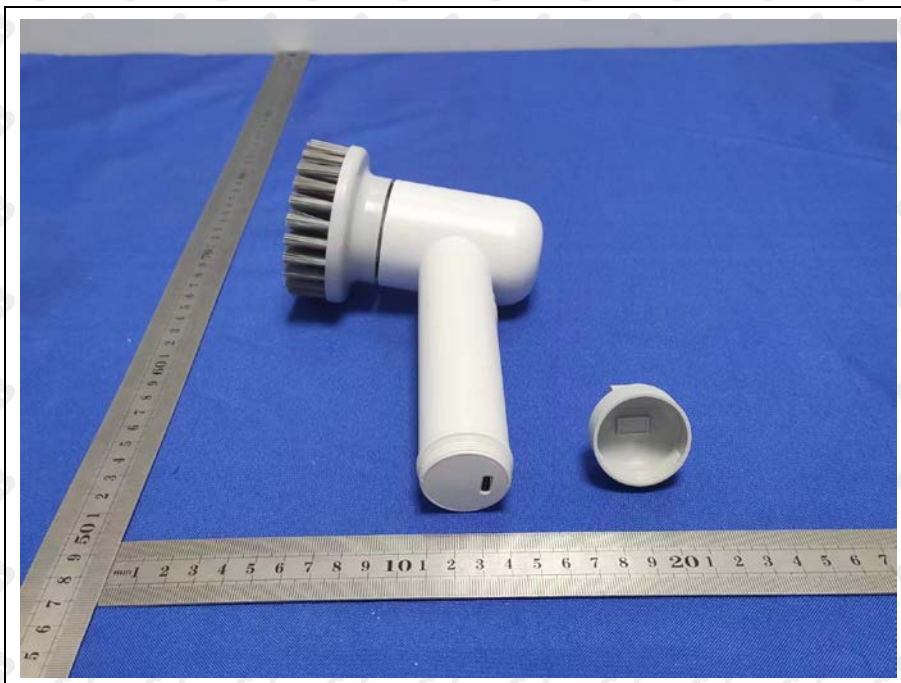

EUT photo 7

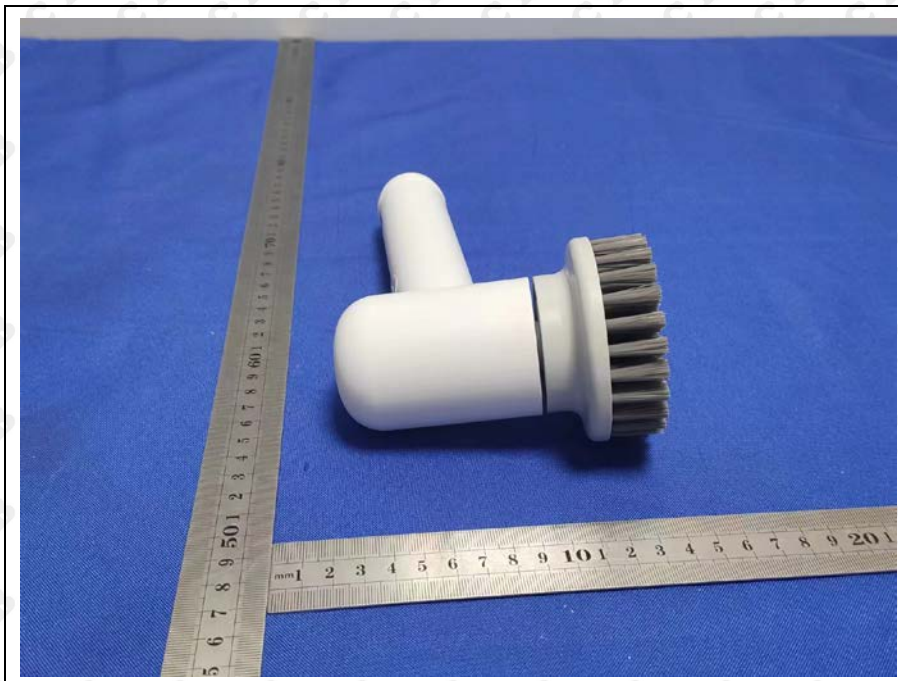

\*\*\*End of report\*\*\*

# CERTIFICATE OF CONFORMITY

EU - Electromagnetic Compatibility (EMC) -

No.: CTB221124009EX -ZS

**Applicant** : Dongguan Shangyin Technology Co., Ltd  
**Address** : Room501, Building 1, No. 11 Bulong Industrial First Road, Fenggang Town,  
Dongguan City, Guangdong Province  
**Manufacturer** : Dongguan Shangyin Technology Co.,Ltd  
**Address** : Room501, Building 1, No. 11 Bulong Industrial First Road, Fenggang Town,  
Dongguan City, Guangdong Province  
**Product** : Multi-function ELECTRIC CLEANING BRUSH  
**Trade Mark** : /  
**Model(s)** : Q1, Q2, Q3, Q4, Q5, Q6, Q7, Q8, Q9, Q10  
**Test Report No.** : CTB221124009EX  
**Test Standards** : EN IEC 55014-1:2021, EN IEC 55014-2:2021

The tests that base on the above designated product Complies with the essential requirements of Directive 2014/30/EU relating to Electrical Equipment designed for use within Electromagnetic Compatibility.

The test results apply only to the particular sample tested and the applicative tests carries out.

The CE marking as shown below can be affixed on product after manufacturer carries out all stipulation activities integrally of above-mentioned Regulation (Directive) and preparation of necessary technical documentation as well as the conformity declaration.

This statement is based on a single evaluation of sample of above-mentioned product. It does not imply an assessment of the whole production process.

Other relevant Regulation (Directive) requirement have to be observed.



**Shenzhen CTB Testing Technology Co., Ltd**

Add: 1&2/F., Building A, No.26, Xinhe Road, Xinqiao, Xinqiao Street, Bao'an District, Shenzhen, Guangdong, China.

Web: [www.ctb-lab.net](http://www.ctb-lab.net) Tel: 4008-707-283 Email: [ctb@ctb-lab.net](mailto:ctb@ctb-lab.net)

# CERTIFICATE OF CONFORMITY

**UKCA - Electromagnetic Compatibility Regulations 2016**

**(SI 2016 No. 1091, as amended by SI 2019 No. 696)**

**No.: CTB221124011EX-ZS**

**Applicant** : Dongguan Shangyin Technology Co., Ltd  
**Address** : Room501, Building 1, No. 11 Bulong Industrial First Road, Fenggang Town,  
Dongguan City, Guangdong Province  
**Manufacturer** : Dongguan Shangyin Technology Co., Ltd  
**Address** : Room501, Building 1, No. 11 Bulong Industrial First Road, Fenggang Town,  
Dongguan City, Guangdong Province  
**Product** : Multi-function ELECTRIC CLEANING BRUSH  
**Trade Mark** : /  
**Model(s)** : Q1, Q2, Q3, Q4, Q5, Q6, Q7, Q8, Q9, Q10  
**Test Report No.** : CTB221124011EX  
**Test Standards** : BS EN IEC 55014-1:2021, BS EN IEC 55014-2:2021

The tests that base on the above designated product Complies with the essential requirements of Electromagnetic Compatibility Regulations 2016(SI 2016 No. 1091, as amended by SI 2019 No. 696) relating to Electrical Equipment designed for use within Electromagnetic Compatibility.

The test results apply only to the particular sample tested and the applicative tests carried out.

The UKCA markings as shown below can be affixed on product after manufacturer carry out all stipulation activities integrally of above mentioned Regulation(Directive) and preparation of necessary technical documentation as well as the conformity declaration.

This statement is based on a single evaluation of sample of above mentioned product. It does not imply an assessment of the whole production process.

Other relevant Regulation(Directive) requirement have to be observed.

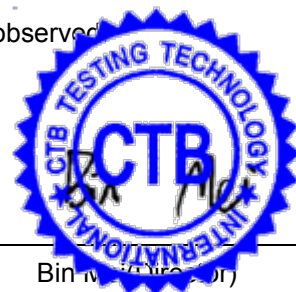

Bin w  
2022

Nov. 28, 2022



**Shenzhen CTB Testing Technology Co., Ltd**

Add: 1&2/F., Building A, No.26, Xinhe Road, Xinqiao, Xinqiao Street, Bao'an District, Shenzhen, Guangdong, China.

Web: [www.ctb-lab.net](http://www.ctb-lab.net)

Tel: 4008-707-283

Email: [ctb@ctb-lab.net](mailto:ctb@ctb-lab.net)